



4" Duct (Standard):
 80 CFM/1.5 Sones @ 0.1 SP, 10.5 Watts
 54 CFM @ 0.25 SP, 8.2 Watts



Description

Low noise ceiling mount ventilating fan, LED dimmable light, and heat. Contemporary grille with LED included. cUL listed and Home Ventilating institute (HVI) certified.

DC Motor/Blower

- Power rating of 120 volts/60Hz
- DC brushless motor engineered to run continuously
- Motor equipped with thermal cutoff fuse
- Removable with permanently lubricated plug-in motor Built-in soft start function to increase bearings' life
- Automatically powers OFF when impeller is locked abnormally

Housing

- Galvanized steel body
- Detachable 4" diameter duct adapter
- Built-in backdraft damper
- Easy installation

Grille

- Attractive design using PBT material
- Attaches directly to housing with torsion springs

Light

- 13-Watt LED included
- Light output 850 Lumens, 2700K
- Dimmable Lighting (dimmer switch not included)

Heater

- 1300W heating element evaluated by cUL for safety standards
- Heater module equipped with thermal cutoff fuse and thermostat

Warranty

- 3-Year limited warranty

pressure. Power consumption approximately 11.7 Watts with an efficiency rating approximately 7.0 CFM/Watt. Duct diameter no less than 4" Built-in thermostat to regulate temperature. Metal guard to help prevent user contact with heating wire. Heater element with 1300W and conforms to cUL safety standards. Heater module equipped with thermal cutoff fuse and thermostat.

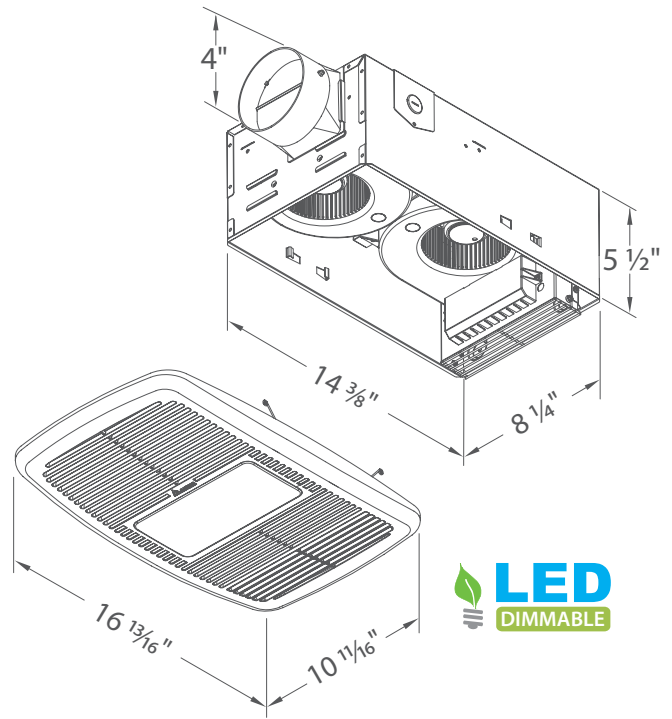

TYPICAL SPECIFICATION

Ventilation fan shall be model RAD80LED; brushless DC motor engineered to run continuously for a minimum 70,000 hours; airflow rating of 80 CFM (±10%) and 1.5 Sones at 0.1 static

BreezRadiance RAD80LED		
	4" Duct (Standard)	
Static Pressure (Inches w.g.)	0.1	0.25
Air Flow (CFM)	80	54
Sones	1.5	N/A
Power Consumption (Watts)	11.7	8.2
Energy Efficiency (CFM/Watts)	7.0	6.4
Current (Amps)	11	
Power Rating (V/Hz)	120/60	
Heating element (Watts)	1300	
Total power (Watts)	1314	

RAD80LED Fan Curve

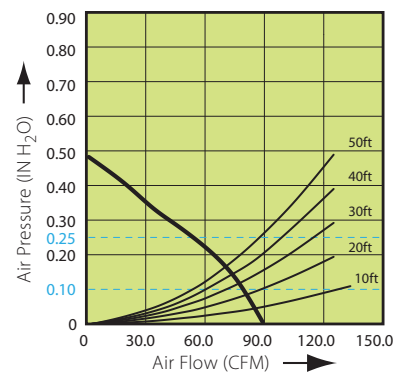

Model	Quantity	Comments	Project:
			Location:
			Architect:
			Engineer:
			Contractor:
			Submitted by:
			Date: